

# HQ HEATING SDN. BHD

## 3 X 3mm Brighted Surface Stainless Steel Mineral Insulated Coil Heater Built In Type 'K' Thermocouple (Straight Length fully annealed)

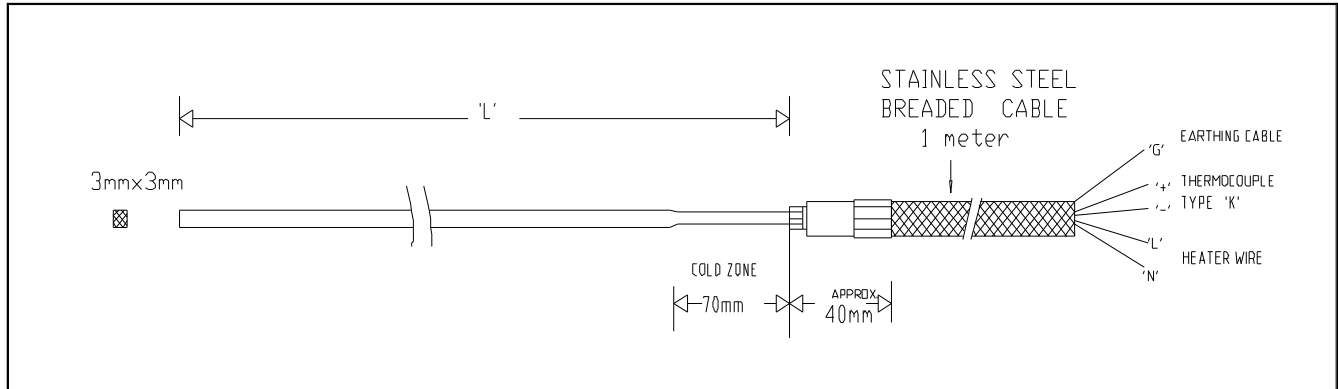

Model	Voltage (V)	Wattage (W)	'L' (mm)
HQMIH (3x3)230 x 150watt-L350-K	230	150	350
HQMIH (3x3)230 x 180watt-L400-K	230	180	400
HQMIH (3x3)230 x 200watt-L450-K	230	200	450
HQMIH (3x3)230 x 250watt-L500-K	230	250	500
HQMIH (3x3)230 x 300watt-L600-K	230	300	600
HQMIH (3x3)230 x 400watt-L750-K	230	400	750
HQMIH (3x3)230 x 500watt-L900-K	230	500	900
HQMIH (3x3)230 x 600watt-L1100-K	230	600	1100
HQMIH (3x3)230 x 800watt-L1400-K	230	800	1400
HQMIH (3x3)230 x 1000watt-L1700-K	230	1000	1700

### Application:

Suitable to install for Extrusion Machine to heat up the nozzles.  
Heating piping system , Heat tracing for pipes and etc.

Note: Above are standard and exstock item and also provide custome require size and rating.